

# Next Generation UltraGrip Flange Adaptors

Datasheet 1/2

## Flange Adaptor Type 1

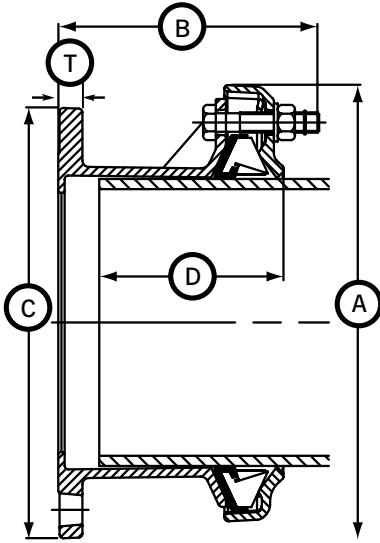

## Flange Adaptor Type 2

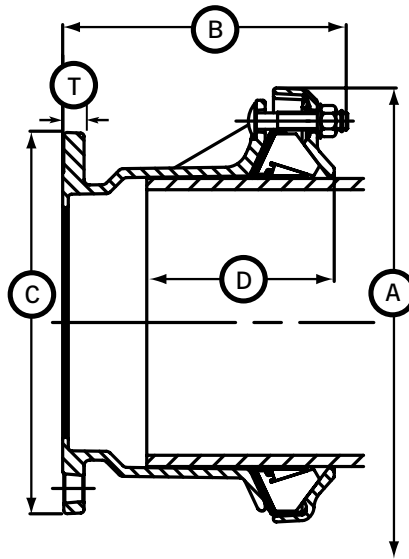

## UltraGrip Flange Adaptors

Nom Size	Size Range		Flange Nom Size	Flange Drilling	Type	Insertion Depth (D)		Dimensions				Bolts		Weight (kg)
	Min	Max				Min	Max	C	A	B	T	No-size	Type	
40	43.5	63.5	40	PN10,16	1	65	110	150	168	164	17.0	3-M12 x 70	HRH	4.4
40	43.5	63.5	50	PN10,16	1	65	110	165	168	164	17.0	3-M12 x 70	HRH	4.83
50	48.0	71.0	50	PN10,16	1	65	110	165	178	163	17.0	3-M12 x 70	CSX	4.83
65	63.0	83.7	60/65	PN10,16	1	65	110	185	189	162	17.0	3-M12 x 70	HRH	5.68
65	63.0	83.7	65	PN10,16	1	65	110	185	189	164	17.0	3-M12 x 70	HRH	5.87
80	85.7	107.0	80	PN10,16	1	65	110	200	212	164	17.0	3-M12 x 70	HRH	6.82
100	107.0	133.2	100	PN10,16	2	90	125	220	280	212	17.0	3-M16 x 90	HRH	10.17
125	132.2	160.2	100	PN10,16	2	90	135	220	305	243	17.0	3-M16 x 90	HRH	11.5
125	132.2	160.2	125	PN10,16	1	90	135	257	305	193	17.0	3-M16 x 90	HRH	11.19
125	132.2	160.2	150	PM10,16	1	90	135	285	305	194	17.0	3-M16 x 90	HRH	12.6
150	158.2	192.2	150	PN10,16	2	90	125	285	339	232	17.0	4-M16 x 90	HRH	14.72
175	192.2	226.9	200	PN10,16	2	125	165	340	403	263	18.0	5-M16 x 93	CSX	24.32
200	218.1	256.0	200	PN10,16	2	125	165	340	432	263	18.0	5-M16 x 93	CSX	25.75
250	266.0	310.0	250	PN10,16	2	125	165	404	476	323	20.0	6-M16 x 120	HRH	36.23
300	315.0	356.0	300	PN10,16	2	125	200	469	522	324	21.5	8-M16 x 120	HRH	44.5
350	352.2	396.0	350	PN10,16	2	125	200	520	577	333	21.5	9-M16 x 120	CSX	51.75
400	398.2	442.0	400	PN10,16	2	125	200	580	623	333	21.5	10-M16 x 120	CSX	58.46
450	448.0	492.0	400	PN10,16	2	135	215	580	713	413	24.0	12-M16 x 140	HRH	97.42
450	448.0	492.0	450	PN10,16	2	135	215	640	710	409	27.0	12-M16 x 140	HRH	101.0
500	498.0	552.0	500	PN10,16	2	155	215	715	803	398	27.5	9-M20 x 150	HRH	115.78
500	558.0	608.0	500	PN10,16	2	155	215	715	860	448	27.5	10-M20 x 150	HRH	130.09
600	604.0	648.0	600	PN10,16	2	195	255	840	900	454	31.0	12-M20 x 150	HRH	170.97
600	676.0	726.0	600	PN10,16	2	195	255	840	975	454	31.0	14-M20 x 150	HRH	195.36

Flange Drilling - All flanges are drilled to BS EN 1092 (formerly BS 4504) 7005\* with the rating as per table

\* There are several parts to these standards to suit different flange materials:

1. BS EN 1092 PT1 2. BS EN 1092 PT2 3. BS EN 1092 PT3 4. BS EN 1092 PT4 5. ISO 7005-1 6. ISO 7005-2 7. ISO 7005-3

## Working Pressure & Temperature Ratings

Nominal Size	Gripping Product		Flex Product		Operating Temperature
	Gas	Water	Gas	Water	
DN40 to DN300	5 bar	16 bar	5 bar	16 bar	-20°C to +30°C
DN350 to DN400	5 bar	10 bar	5 bar	10 bar	
DN450 to DN600	N/A	10 bar	N/A	10 bar	

### Notes:

- 1) Site Test Pressure – 1.5 times working pressure.
- 2) Factory Test Pressure – The minimum requirement in European Standards is 1.5 times working pressure plus 5 bar (e.g. 29 bar for 16 bar working pressure).
- 3) All water contact components are approved for use with Potable Water.

Bolt Torque	
	Nm
M12	55 - 70
M16	95 - 120
M20	210 - 230

Every effort has been made to ensure that the information contained in this publication is accurate at the time of publishing. Crane Ltd assumes no responsibility or liability for typographical errors or omissions or for any misinterpretation of the information within the publication and reserves the right to change without notice.

# Next Generation UltraGrip Flange Adaptors

Datasheet

2/2

## Technical Information

### Gripping product suitable for

Steel / Ductile iron / Grey cast iron / PE / PVC

### Flex product suitable for

Steel / Ductile iron / Grey cast iron / PVC / Asbestos cement

### Full flange sealing face suitable for

Water-type butterfly valves

### Angularity

Flange Adaptors 4°

### Support liners – PE and PVC pipes

A close fit support liner is required when used on:

- ▶ All PE pipes
- ▶ Thin walled PVC pipes

When used on thick walled PVC pipes a support liner is not required. Please contact Viking Johnson for further details.

### Use of restrained couplings on exposed pipework

Above ground exposed pipework is subject to both loads from the internal pressure and those from temperature changes / thermal expansion, which can be substantially higher than those from internal pressure and cannot always be safely determined. For this reason it is recommended that the use of UltraGrip be restricted to buried pipelines, valve chambers and above ground indoor applications and not exposed to direct sunlight or excessive temperature changes (e.g. pump houses).

### Approvals

The following water contact materials used in UltraGrip are approved for use with potable water:-

Rilsan Nylon 11:

- ▶ WRAS, KIWA, AS/NZS 4020

Gasket (EPDM):

- ▶ WRAS, KTW, DVGW, W270, KIWA & AS/NZS 4020

In addition to the above, UltraGrip range as a finished product has KIWA certification verifying that the above products comply with the requirements of the Water Supply (Water Fittings) Regulations for England and Wales 1999, the Water Byelaws 2000, Scotland and the Water Regulations Northern Ireland.

Gasket (Nitrile):

- ▶ DVGW Approved

DN40 to DN600 UltraGrip has been independently tested by BSI to confirm it meets the requirements of BS EN 14525 (VC 673979).

## Materials & Relevant Standards

### End Ring & Adaptor Body/Centre Sleeve

S.G. Iron to BS EN 1563 Symbol EN-GJS-450-10

### Gasket

EPDM Compound Grade E to BS EN 681-1

Nitrile Compound to Grade G BS EN 682, Type G

### Gripper & Carrier

Acetal Copolymer Grade M25 or equivalent

### Coatings

Cast/Metal Components:

- ▶ Rilsan Nylon 11 (Black)

Bolts:

- ▶ Delta Seal GZ - Silver

Nuts:

- ▶ Delta Seal GZ - Silver

### Bolts

Standard - Stainless steel to BS EN 3506-1 Grade A2 Property Class 80 or 70

Option - Stainless steel to BS EN ISO 3506-1 Grade A4 Property Class 50

### Nuts

Stainless Steel to BS EN 3506-2 Grade A4 Property Class 80

### Washers

Stainless steel – BS1449:PT2 Grade 304 S15

### Grit to Gripper

Corundum - aluminium oxide with a chemical composition of  $Al_2O_3$  and a hexagonal crystal structure (rock-forming mineral that is found in igneous, metamorphic, and sedimentary rocks).

Every effort has been made to ensure that the information contained in this publication is accurate at the time of publishing. Crane Ltd assumes no responsibility or liability for typographical errors or omissions or for any misinterpretation of the information within the publication and reserves the right to change without notice.